

TWIN IMPELLER "FIREFIGHTER® PLUS"
 (13HP ELECTRIC START ENGINE)
 Model Numbers: 93274E & 93276E

DEPEND ON
DAVEY

PUMPS

SELF PRIMING PUMPS



PRODUCT DESCRIPTION

Rugged, economical twin impeller self priming pump. These units are driven by either a 13HP Briggs & Stratton "Vanguard" engine or a 13hp Honda GX390E engine, fitted with an electric start.

APPLICATIONS

- High pressure firefighting
- Tanker to tanker water transfer
- High head general water transfer
- Sheep jetting
- Irrigation
- Boom spraying
- Travelling irrigators

FEATURES & BENEFITS

Twin impeller design provides the versatility of extra pressure when required or lower engine speed for longer life.

Pump casing, diffusers and impellers manufactured from quality corrosion resistant marine grade aluminium for long life.

3 way discharge port for easy installation with a choice of plumbing sizes.

Epoxy coated pump exterior for added corrosion resistance.

Replaceable wear rings ensure continued high efficiency pumping.

Low-oil protection on all models - engines won't start or run if oil level is inadequate, thus protecting your engine.

All engines feature cast iron cylinder bore for long life.

Oversize engine with power reserves for long life.

Proven robust design assures operators of continuing performance.

Electric starter (battery and leads required) and recoil starter fitted, ensures a choice of starting methods, even if the battery is flat or removed.

Self priming from 6m for more versatile installation options.

Viton seal and oring kit available for herbicide/insecticide spraying.

All engines conform to the tough environmental requirements of the USA EPA and CARB standards, to help look after the environment.

OPERATING LIMITS

Flows to	480 lpm
Maximum total head	107m
Maximum suction Lift	6m
Maximum water temperature	50°C
Minimum water temperature	1°C
Minimum suction pipe size	1 1/2"
Suction pipe strainer	Required
Inlet size	1 1/2" BSP(M)
Outlet sizes	1 x 1 1/2" BSP(M) 2 x 1" BSP(M)



TECHNICAL SPECIFICATIONS

MATERIALS OF CONSTRUCTION

PART	MATERIAL
Suction cover	Marine grade aluminium (AS605)
Diffusers	Marine grade aluminium (AS605)
Impellers	Marine grade aluminium (AS605)
Yoke	Marine grade aluminium (AS605)
3 way discharge	Marine grade aluminium (AS605)
Casing bolts	Zinc Plated Steel
Yoke bolts	Stainless Steel
Flap valve	Zinc Body, Rubber Seal
Seal ring	Nitrile Rubber
Neck ring insert	Glass Filled Nylon
Casing oring	Nitrile Rubber

HYDRAULIC PERFORMANCE

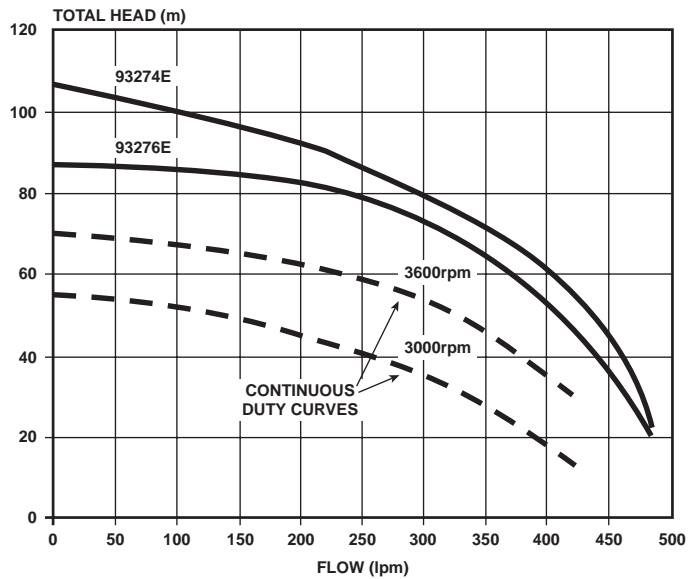

ENGINE SPECIFICATIONS

Engine Brand	Briggs&Stratton	Honda
Engine Model	Vanguard	GX390E
Twin Stage Pump Model	93274E	93276E
"Out of box" governed max engine speed @ no load	4250rpm	3800rpm
Max. rated hp @ 3600rpm	13.0	13.0
Displacement (cc)	391	389
Fuel Tank (litres)	7.9	6.5
Approx. fuel consumption @ full load @ 3600rpm	4.68	3.25
Running time per tank @ full load @ 3600rpm	1.7	2.0
Oil Capacity (litres)	1.5	1.1
Spark arrestor	Yes	No
dBa @ 3600rpm @ full load	81.5 @ 4m	78.0 @ 7m

DIMENSIONS

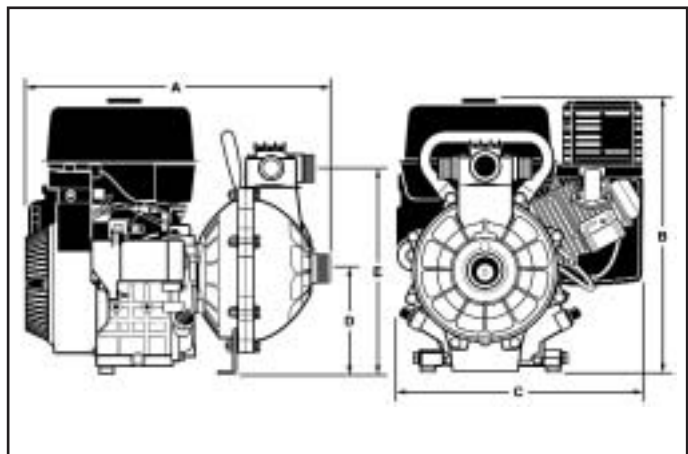

Model	A	B	C	D	E	Inlet BSP	Outlet BSP	Net Weight kg.
93274E	555	485	465	148	315	1 1/2"	2 x 1" 1 x 1 1/2"	40.9
93276E	540	440	450	148	35	1 1/2"	2 x 1" 1 x 1 1/2"	38.7

All dimensions in mm unless otherwise stated.

INSTALLATION & PRIMING

- Fit strainer to bottom of suction pipe; a foot valve is not required
- To prime, fill pump body with water then allow pump to run until drawing water

This literature is not a complete guide to product usage. Further information is available from your Davey dealer, Davey Customer Service Centre and from the relevant product Installation and Operating Instructions. This data sheet must be read in conjunction with the relevant product Installation and Operating Instructions and all applicable statutory requirements. Product specifications may change without notice.

© Davey is a registered trademark of Davey Products Pty Ltd. © Davey Products Pty Ltd 2001.

DEPEND ON
DAVEY

PUMPS

Davey Products Pty Ltd

Member of the GUD Holdings Ltd Group
 ABN 18 066 327 517
 Head Office and Manufacturing
 6 Lakeview Drive,
 Scoresby, Australia 3179
 Ph: +61 3 9730 9222
 Fax: +61 3 9753 4100
 Website: www.davey.com.au
 Customer Service Centre
 Ph: 1300 367 866
 Fax: 1300 369 119
 E-mail: sales@davey.com.au
 Interstate Offices
 Sydney - Brisbane - Adelaide
 Perth - Townsville

International
 6 Lakeview Drive,
 Scoresby, Australia 3179
 Ph: +61 3 9730 9121
 Fax: +61 3 9753 4248
 E-mail: export@davey.com.au

Germany
 Kantstrasse 47,
 04275 Leipzig
 Ph: +49 341 301 0412
 Fax: +49 341 301 0413
 E-mail: DaveyEurop@aol.com

New Zealand
 220A Bush Road,
 North Harbour, Auckland 1330
 Ph: +64 9 914 3680
 Fax: +64 9 914 3685
 Website: www.daveynz.co.nz
 E-mail: sales@daveynz.co.nz

USA
 1005 N. Commons Drive
 Aurora, Illinois 60504
 Ph: +1 630 898 6976
 Fax: +1 630 851 7744
 Website: www.daveyusa.com
 E-mail: sales@daveyusa.com